

# PRODUCT INFO

## ACCESSORY-PACK

Waterproof small additional bag

PVC free

IP 64

PS21R

PS33

PFAS free

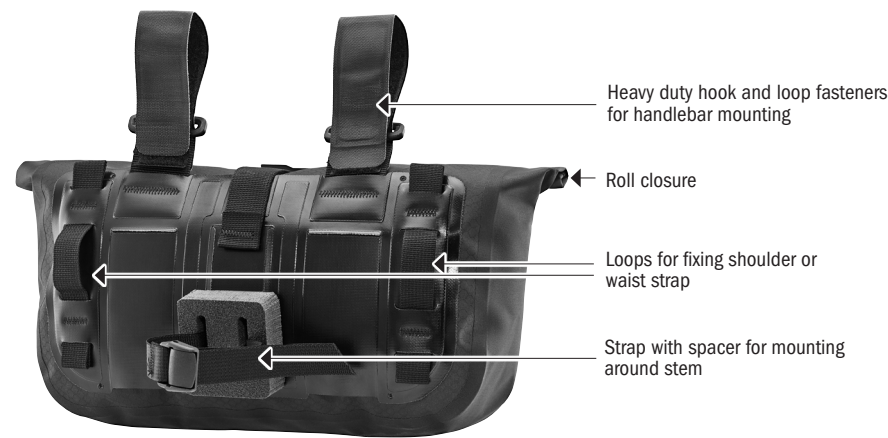

Can be used as a shoulder or hip bag with included strap



More capacity: Accessory-Pack mounted to Handlebar-Pack (optional accessory)

height cm/in	width cm/in.	depth cm/in.	vol. L/cu.in.	weight g/oz.	max. capacity kg/lbs.
17/6.7	30/11.8	5/2	3.5/214	206/7.3	1/2.2

## SPECIFICATIONS:

- + Waterproof Accessory-Pack with roll closure
- + Ideal accessory bag for extra gear, perfect for small stuff such as cell phones, energy bars, GPS etc.
- + Can be used independently as a handlebar bag, or fixed to the Handlebar-Pack for additional quick access storage
- + Can be used as a shoulder bag or hip pouch with the included waist strap
- + Light weight sturdy PU laminated rip stop nylon
- + Mounts to Handlebar-Pack at four locations, utilizing four webbing loops and heavy duty alloy hooks
- + Heavy duty hook and loop fasteners for mounting directly to the handlebar
- + Can be mounted to carbon handlebars
- + Reflective logo
- + Maximum capacity: 1 kg/2.2 lbs.

**Contents:** Accessory-Pack with waist strap

**Optional accessory:** Handlebar-Pack

**Note:** In order to meet standard IP64 (6=dustproof, 4=protected against splash water coming from all directions) the closure must be rolled 3-4 times.

