

PRODUCT INFO

GRAVEL-PACK

Waterproof panniers (pair) with QL2.2 system



- ← Handle for mounting and releasing the QL2.1 system
- ← Additional closure with buckle and D-ring (when bag is carried with shoulder strap)
- ← D-ring for fixing shoulder strap (optional accessory)
- ← Buckles for closing roll closure at the top or for attaching shoulder strap
- ← Highly reflective 3M Scotchlite reflector on both sides
- ← Sturdy rip stop nylon fabric

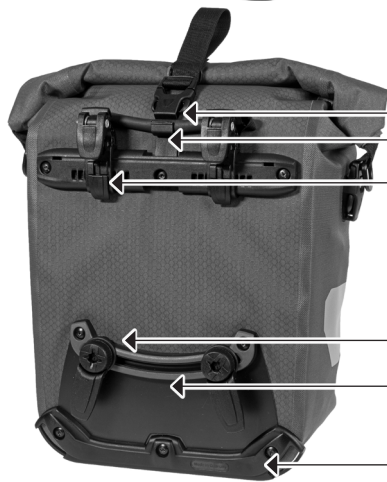

- ← Handle for attaching and releasing the Quick-Lock 2.2 system
- ← Injection-molded auxiliary fastener for attaching the handle and for easier operation of the plug
- ← Self-closing QL2.2 hooks with anti-scratch coating, individually adjustable
- ← 2 sliding and rotating locking hooks with anti-scratch coating, freely adjustable and rotatable on the rail in 15° increments, adjustable from 10-18mm
- ← Hook rail made of two-component synthetic with anti-scratch function
- ← Edge protector with slots for mounting the ORTLIEB carrying system

- PVC free**
- IP 64**
- Anti scratch**
- QL2.2 system**
- PS21R**
- PS33**
- PFAS free**

Height cm/in	Width cm/in	Depth cm/in	Volume L/cu.in.	Weight g/oz.	max. capacity kg/lbs.
37/14,6	26/10,2	12/4,7	29/1770 (pair)	1280 / 45.2 (pair)	2x 12,5/27,6

SPECIFICATIONS:

- + Waterproof pannier with roll closure
- + Ideal pack for bikepacking, alp crossing and trekking tours
- + Light weight, sturdy PU laminated rip stop nylon fabric
- + QL2.2 system
- + Top QL hooks and lower sliding hook adjustable on different diameters without requiring any tools
- + Lower hook rail made of two-component „hard-soft“ synthetic reduces abrasions on carrier
- + Symmetrical shape allows use on right or left side
- + Highly reflective 3M Scotchlite reflectors

Contents: Panniers come as a pair

Optional accessories: Carrying System Bike Pannier (F35), Anti-Theft-Device (E124), Commuter Insert S, Shoulder Strap (E172), QL2.1 hook 18 mm (E211), QL2.1 hook 20 mm (E193); QL2-Lock/QL2-Lock keyed alike (F3913/F3915)

Attention: Maximum load per pannier is 12,5kg / 27.6 lbs. We recommend weighing each loaded pannier to confirm that the maximum allowance of the pannier fixation is not exceeded. This practice is advised for both rear and front panniers. **CAUTION:** The maximum weight capacity of every carrier model is different. Please observe the maximum weight allowance of the carrier fitted to your bicycle. Note: Sometimes the maximum capacity of the panniers fixing system can exceed the maximum capacity of the carrier. **DO NOT** exceed the maximum capacity of the carrier! Note, that the use of panniers will significantly influence the handling properties of your bicycle.

Note: In order to meet standard IP64 (6=dustproof 4=protected against splash water coming from all directions) the lid must be rolled 3-4 times.

